



A guide with practical advice and further recommendations.

Stefan Hildebrandt, LAUFFER Head of Sales,
Forming Technology
© Maschinenfabrik Lauffer GmbH & Co. KG

HOW TO ENSURE YOUR COMPETITIVENESS
IN TIMES OF ENERGY TRANSITION WITH
SERVO-HYDRAULIC PRESSES.



HOW YOU CAN USE SERVO-HYDRAULIC PRESSES TO ENSURE YOUR COMPETITIVENESS IN TIMES OF ENERGY TRANSITION.

A GUIDE WITH PRACTICAL ADVICE AND FURTHER RECOMMENDATIONS.

Stefan Hildebrandt, LAUFFER Head of Sales, Forming Technology
© Maschinenfabrik Lauffer GmbH & Co. KG

Productivity, efficiency and sustainability, were and are, important criteria for decision-making in investment projects. This is even more true in times of energy transition, high inflation and for investments that have a long-term impact.

In addition, there are many technical possibilities and combinations for the drive concept of hydraulic presses, which play out their individual advantages depending on the application. For some years now, solutions with servo technology have been increasingly advertised with a wide range of benefits. However, the buyer unfortunately rarely has the time and expertise to look in detail with the available options and is often disoriented by the extensive offers and the associated promises.

This guide provides you with assistance and advice for choosing the appropriate press system for the industrial production of stamped or formed metal and composite components. The evaluation takes place based on an operating cost analysis that considers both the holistic acquisition costs and the ongoing costs for operation and maintenance. The relevant parameters are in the field of tension and include a large number of technical and business aspects, which are outlined in [Figure 1 \(see page 2\)](#).

Finally, the guide shows sensible options that can significantly increase the overall efficiency of the modern hydraulic press with minimal additional investment.

CONTENTS:

METALFORMING TECHNOLOGY	2
DECISION CRITERIA FOR SERVO TECHNOLOGY	2
DRIVE PRINCIPLES AT A GLANCE	3
1. Traditional constant direct drive with variable pump and throttle valves (open circuit)	3
2. Servo direct drive with constant pumps (open circuit)	4
3. Servo direct drive with variable pumps (semi-closed circuit)	5
GREAT ADVANTAGES WITH SERVO DRAW CUSHION DRIVE	6
THREE STEPS TO THE RIGHT DRIVE CONCEPT	7
Step 1: Analysis of the product portfolio and forming operations	7
Step 2: Create product clusters	8
Step 3: Selection of the press with the right drive concept	8
FURTHER OPTIONS TO INCREASE EFFICIENCY	11
DIVERSITY REQUIRES COMPETENCE	13



METALFORMING TECHNOLOGY

DECISION CRITERIA FOR SERVO TECHNOLOGY



Figure 1: Decision criteria for servo drive technology





Before the selection of a drive concept is presented in a few simple steps, a brief overview of three selected technologies and their advantages and disadvantages will first be shown.

DRIVE PRINCIPLES AT A GLANCE

OVERVIEW OF THE HYDRAULIC PRESS DRIVES

1. Traditional constant direct drive with variable pump and throttle valves (open circuit)

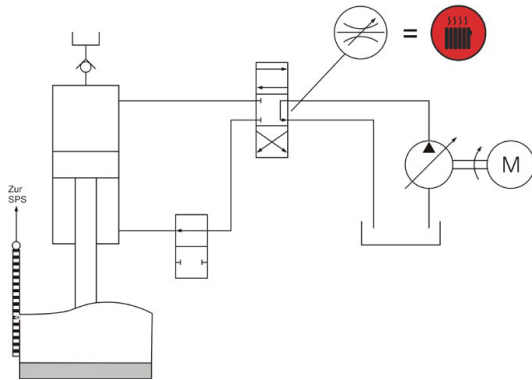

Figure 2: Traditional hydraulic drive

The traditional constant direct drive has been used since the early beginnings of hydraulic press technology and convices with proven and robust components. The motor drive is a standard asynchronous motor with constant speed (at 60Hz approx. 1770 rpm). An axial piston variable displacement pump is usually used as a pump, which can vary its flow rate through a swash plate. A valve block with proportional technology is used to control the actuator movement. A differential cylinder is usually used as an actuator in press hydraulics.

Conclusion:

- + Proven components
- + Limited idle and standby function
- + Wide range of applications

- Throttle losses in valves
- High cooling capacity required
- Large tank volume
- Wear and leakage on valves
- Positioning can only be accomplished by additional valves

Assessment

Motor: Asynchronous motors are available in standardized sizes and performance classes.

Due to soft start modules and constant speed, no high peak loads are required, but reactive power is also emitted into the grid due to the phase shift of current and voltage during charging and discharging of the inductors ($\cos \phi$). This must be compensated for by appropriate technical countermeasures, otherwise there is a risk of severe fines by the energy supplier.

The electric motor can also be operated at variable speed by using a frequency converter. However, due to the high inertia of the motor and the typical torque-speed characteristics, it is not suitable for sufficiently precise speed or position control but can at least be used for throttling down or complete power down during longer downtimes.

Pump: Variable displacement axial piston pumps are very proven and robust working devices.

The available displacement volumes are finely structured and cover a wide range. Combinations of two pumps on one shaft are also possible. The selection of the pump regulator is also important: Depending on the type of pump and manufacturer, there are different technical versions. They have a major influence on the performance of the overall system.

Motion control: The driving movement is controlled by a proportional spool valve, which is used to control the oil volume flow. It is severely lossy in throttle mode and, due to the cross-sectional taper, creates oil heating, which must be cooled again by installing appropriate heat exchangers and providing large oil tanks. The resulting loss is on average 30-40 % of the total output. In terms of position control and speed control, these systems are sufficient.

The speed is controlled by running through one-time stored characteristic curves. Due to a slow wear of the valve control edges, setpoint deviations occur in the medium term, which must be regularly compensated for by recalibration.



2. Servo direct drive with constant pumps (open circuit)

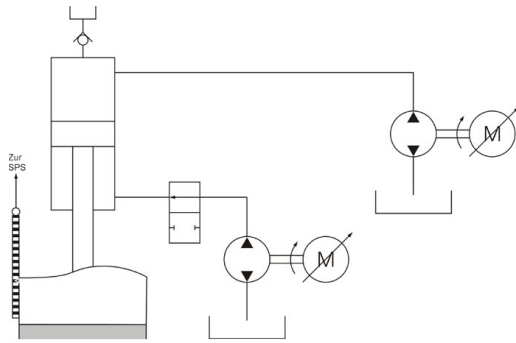

Figure 3: Servo direct drive with fixed displacement pumps

The servo direct drive with fixed displacement pumps uses the properties of the servo motors and regulates the pump flow rate via the speed control. As a result, proportional valve technology can be eliminated. In return, however, another motor-pump unit is required on the ring side of the cylinder in order to initiate the direction of movement of the cylinder on both sides. This also offers advantages for position control and energy efficiency. Pumps and motors run in two quadrants. In the case of larger presses, several motor-pump units may be combined due to the increased flow rate required.

Conclusion:

- + Pump control on demand
- + Lower energy consumption per stroke
- + Reduction of throttle losses
- + Idle and standby function
- + Low recuperation possible during deceleration
- + Good positioning control
- + Reduced oil tank volume
- + Reduced cooling capacity
- + Noise reduction

- Range of applications to be taken into account when designing
- Fixed displacement pumps are more susceptible to wear and tear at high pressure, low flow rates and changes of direction
- Higher number of components, which increases the possibility for failure
- Connected load higher
- Design of the hydraulics strongly dependent on the cycle requirements

Assessment

Motor: Servo motors are available in standardized sizes and performance classes.

Due to the favorable torque-speed characteristics, fast angular accelerations can be achieved, but these also lead to high peak loads. Due to the mode of operation of the frequency converter, no reactive power is emitted into the grid.

However, the design of the motor/pump combination is very much dependent on the press cycle since the maximum torque of the pump is proportional to the pump size and pressure level. Although a servo motor can usually be overloaded for a short time up to 4 times the nominal current, the risk of overheating of the motor during longer pressure maintenance phases increases exponentially.

Precise speed or position control is possible with these drives and they are well suited for a complete power down even with short downtimes.

Pump: Fixed displacement pumps, in this case, mostly internal gear pumps, are also very proven and robust working machines. The available displacement volumes cover a wide range and combinations of two pumps on one shaft are also possible. A pump controller is not required for this application, as this task is performed by the servo motor.

Depending on the selected pump type, the system tends to fail prematurely when used in pressure-holding mode (high pressure, low flow rate) and in cross-quadrant operation (e.g. rapid change of direction of rotation).

Motion control: The control of the travel movement for position and speed is carried out entirely by the speed of the pump. Depending on the desired direction of travel, the piston-side pump is active or the ring-side pump is active. This eliminates the throttle losses described above and makes the overall system more efficient. Positive side effects are a smaller tank volume required and reduced cooling capacity. Position and speed control can be implemented very well with this system.

In particular, due to the individual drive for both the piston and ring side, positioning can be implemented very well. In addition, hydraulic pre-tensioning of the system is possible.



3. Servo direct drive with variable pumps (semi-closed circuit)

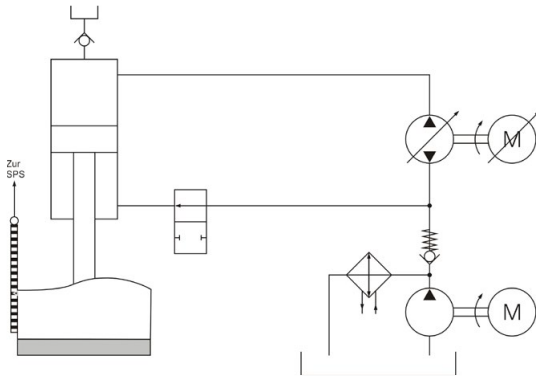

Figure 4: Servo direct drive with variable displacement pump

The servo direct drive with variable displacement pump in a semi-closed circuit regulates the pump flow rate with two parameters. In the power range of the motor, it is controlled by the speed. If the required amount of oil and the pressure level exceed the power of the motor, the flow volume is regulated via the pump swivel angle (classic power control). This allows the motor to be operated at the optimum operating point as far as possible and to work more efficiently. In addition, overheating of the motor is avoided during longer pressure holding phases, as the torque can be reduced. This principle eliminates the need for proportional valve technology. Due to the semi-closed circuit (the pump can pump in both directions and is connected to the actuator on both sides), the unit moves the cylinder in both directions. **This means that the braking energy is also recovered directly in the system when the actuator is decelerated.** Due to the area ratio of the differential cylinder, the oil circuit must be semi-closed, so that the system feeds in the additional oil volume required for the piston side in the downward movement and returns excess oil volume from the piston side to the tank in the upward movement. This requires a small feed circuit with auxiliary drive. In the case of larger presses, several motor-pump units can also be combined modularly to meet the required flow rate.

Assessment

Motor: Servo motors are available in standardized sizes and performance classes.

Due to the favorable torque-speed characteristics, fast angular accelerations can be achieved, but these also lead to high peak loads. However, due to the mode of operation of the frequency converter, no reactive power is emitted into the grid.

Precise speed or position control is easily possible with these drives and they are just as well suited for a complete shutdown even during short idle periods.

Pump: Variable displacement axial piston pumps are very proven and robust working machines. The available delivery volumes cover a wide range with the speed range of the motors.

Motion control: The driving movement for position and speed is controlled by the speed and swivel angle of the pump. Likewise, requirements for very fast step responses can be met by the rapid acceleration of the servo motor from the zero position.

Again, the throttle losses described above are eliminated, the overall system is very efficient. Positive side effects are a small tank volume and significantly reduced cooling capacity. Position and speed control can be implemented very well with this system.

Conclusion:

- + Demand-based pump control
- + Reduction of throttle losses
- + Recuperation during deceleration
- + Idle and standby function
- + Robust components
- + Longer lifespan
- + Reduced oil volume
- + Reduced cooling capacity
- + Noise reduction

– Range of applications to be taken into account when designing



GREAT ADVANTAGES WITH SERVO DRAW CUSHION DRIVE

In principle, all of the drive concepts mentioned can also be transferred to die cushion drives. This is where servo technology paired with the right pump type comes into its own. Depending on the size of the die cushion force and stroke, they are decisive for the profitability of the technology, since the arithmetic product of force and stroke represents a measure of the energy converted.

In conventional systems, this force is applied by an adjustable pressure relief valve. During the forming stroke, the oil is displaced against this valve, the hydraulic valve is discharged into the oil tank and heat losses occur. This hydraulic (loss) energy can be recuperated into electrical energy with modern drives and fed directly to the upper piston drive, thus making a significant contribution to energy efficiency and thus to economic efficiency.

You will soon find examples of what this brings in individual cases when we present customer projects that have already been implemented successfully.

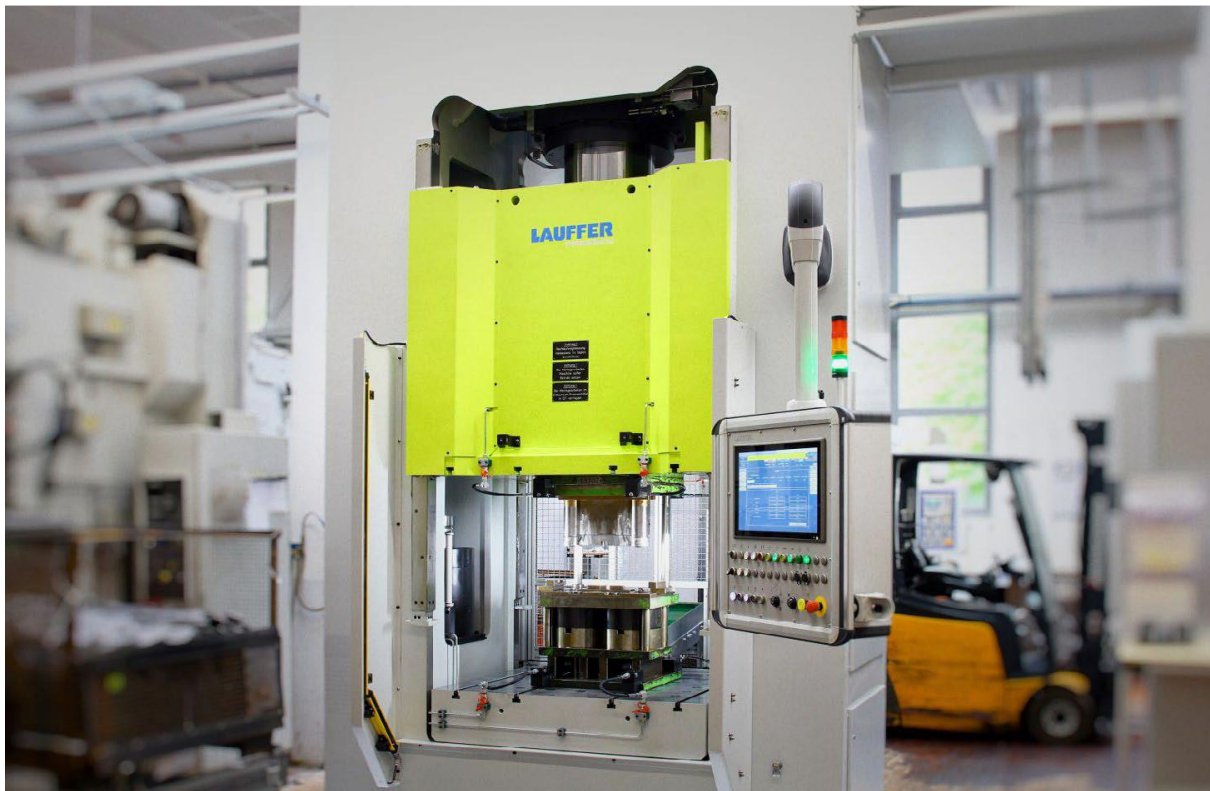



THREE STEPS TO THE RIGHT DRIVE CONCEPT

WITH THESE BASICS, THE SELECTION OF THE APPROPRIATE DRIVE CONCEPT FOR A SPECIFIC APPLICATION CAN NOW BE MADE. TO DO THIS, THREE BASIC STEPS ARE EXPLAINED IN DETAIL.

Step 1: Analysis of the product portfolio and forming operations

Maschinenfabrik LAUFFER offers a wide range of drives for hydraulic presses, ranging from the basic solution, the proven asynchronous motor with constant speed and fixed displacement pump, to the variable-speed servo motor with axial piston variable displacement pump. It is possible to differentiate again according to the functional axis, because, depending on the application, it is more efficient to combine different drive concepts for upper pistons (slide/ram), lower pistons (die cushion) and, if necessary, other secondary axes.

The right solution can be found through an analysis of the range of parts and operating cost accounting.

The following information forms the basis for this:

- **Number of components per year**
The 80/20 method is recommended.
Only those components that account for about 80 % of the total annual production volume on the machine are included in the analysis. This avoids the development of a complex universal machine, which often does not bring the desired amortization due to cost considerations.
- **Method plan, handling method**
Depending on the production and handling method, different travel modes of the press are necessary. Manual handling, coil fed tools, robot handling, progressive or transfer tools require different press opening strokes. This affects the cycle time and thus has a direct impact on the total cost of ownership.
- **Required pressing force**
The required pressing force is always a fundamental criterion for the design of a press. Together with the required cycle time (minimum cycle time) and the associated requirements for the speed of each axis, this has a significant influence on the required drive power of the system.
- **Required counter-holding force (die cushion) and die cushion stroke**
The counter-holding force as well as the required die cushion stroke are also basic criteria for the design of a press. As mentioned before, these variables have a very decisive influence on the principles of sustainability and economic efficiency.
- **Required cycle time**
The cycle time is used to determine the required press speeds and influences the installed drive power and has a direct impact on properly sizing the drive package.
- **Idle time at top dead center for parts handling and/or bottom dead center for flow or reaction processes**
Depending on the duration of idle times, it may be useful to throttle the drive in these phases. This is an important factor in determining the appropriate drive concept.
- **Size of the respective production batches or tool change time and frequency**
This information provides information about the duration and frequency of downtimes when changing tools. The data is incorporated into the profitability calculation and allows further recommendations for a suitable tool change system.



Step 2: Create product clusters

The formation of clusters helps to quickly estimate the required press size and also the preferred drive concept. This makes it easy to see whether, for example, a servo die cushion would make sense and with which stroke it should be equipped. Similar aspects apply to the design of a throttle operation in top or bottom dead center and which pump type is optimal for the application.

Since a multi-dimensional system is created during the formation of the clusters due to the high number of criteria and different focal points have to be defined depending on the production environment, the LAUFFER application specialists are happy to support the creation, analysis and evaluation of the data. The joint discussion provides both sides with important inputs and information for the selection of a suitable machine.

Step 3: Selection of the press with the right drive concept

There is no one-size-fits-all recipe for selecting the right drive. However, the information from the analysis (step 1) and the product clusters (step 2) provide important information for a rough pre-selection.

Some examples from customer practice:

Customer example 1: Conventional main drive with servo drive for the die cushion

Sheet metal forming with homogeneous product portfolio, predominantly die cushion operation, manual handling, longer downtimes only in non-productive times

The product portfolio is relatively homogeneous. 70 – 80 % of the component spectrum requires pressing forces in the range of 300 – 400 tons. Many of these components require a die cushion with 100 – 160 tons for deep-draw strokes between 100 and 150 mm. Usable idle times only occur during the handling time. The operation is one or two-shift.

The press was equipped with a traditional main drive and servo drive in the die cushion. In a representative comparative measurement of two hydraulic presses with the same tool, energy savings of 26 % could be demonstrated. Only 50 % of the die cushion force and only 68 % of the stroke were utilized. A linear extrapolation leads to possible energy savings of up to 33 % in this specific application. If, on the other hand, the additional investment is calculated, this results in a payback of 3 – 4 years, with an underlying electricity price of 20 ct/kWh. In addition, there are further advantages in terms of production technology, for example due to the better control quality of the die cushion force.

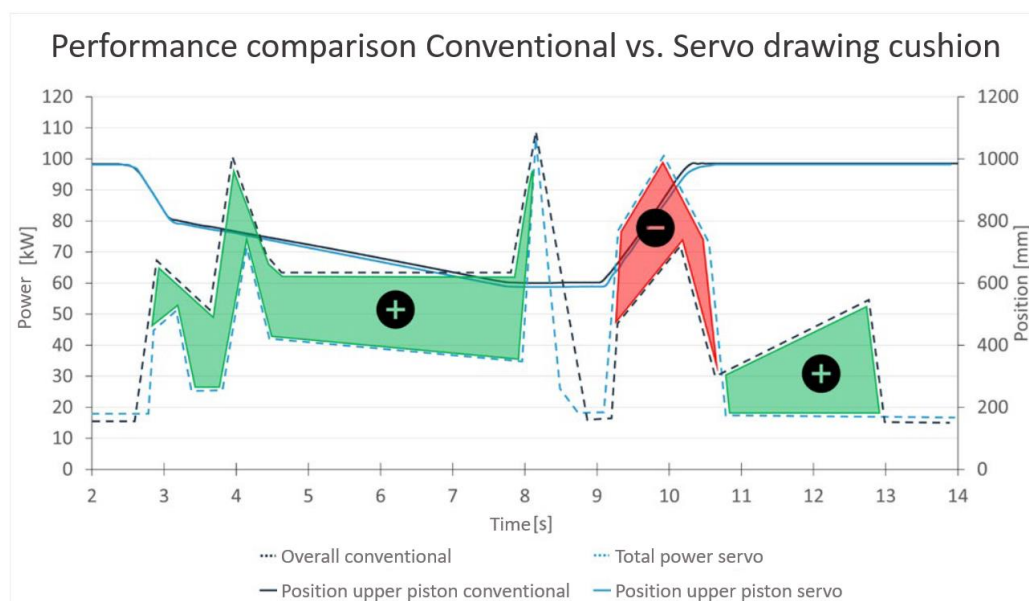

Figure 5: Energy measurement to compare traditional hydraulics with servo die cushions



Customer example 2: Servo motor with fixed displacement pump

Composite components with a small, homogeneous product portfolio, no die cushion operation, manual handling, long idle times with high pressing pressure during consolidation

The customer's product portfolio is small and homogeneous. The components made of glass fiber composites require pressing forces in the range of 600 – 800 tons. The consolidation phase under high pressing pressure takes up to 20 minutes, about 60 – 70 % of the cycle time.

Press types for these or comparable applications are equipped with servo motors and fixed displacement pumps. Due to the long pressure holding times, the travel speed of the ram is not decisive for the design. For good energy efficiency, the motors run at reduced speed during the long holding time and deliver just enough oil to maintain pressure levels and compensate for small internal leaks. Acceleration ramps when the pump is started up are approached gently to avoid large peak loads. The system dispenses with proportional valve technology, so that internal throttle losses are also reduced in favor of the overall energy balance.

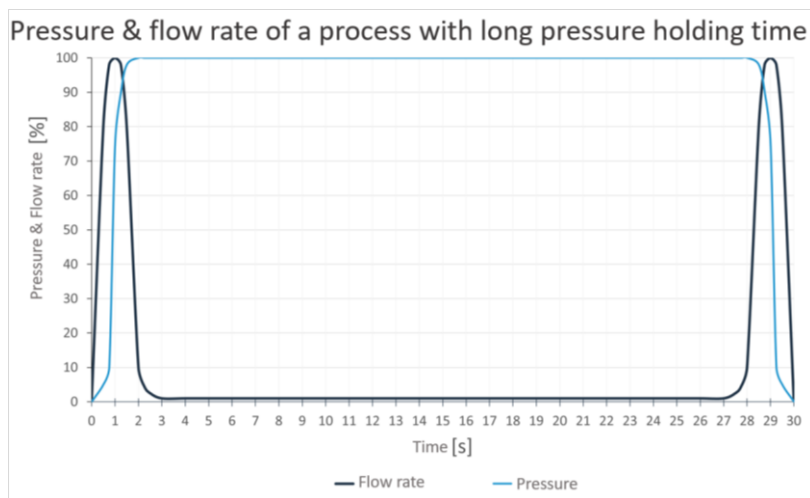

Figure 6: Exemplary cycle of a pressing cycle with a long pressure holding time (simplified)

Customer example 3: Servo motor with axial piston variable displacement pump

Deep-drawn components, large product portfolio, die cushion operation, automatic handling, short downtimes for tool changes, three-shift operation

The product portfolio is extensive and diverse. The proportion of deep-drawn parts made of stainless steel predominates. The forming operations are often at the limit of what is feasible and the components are subject to high quality standards.

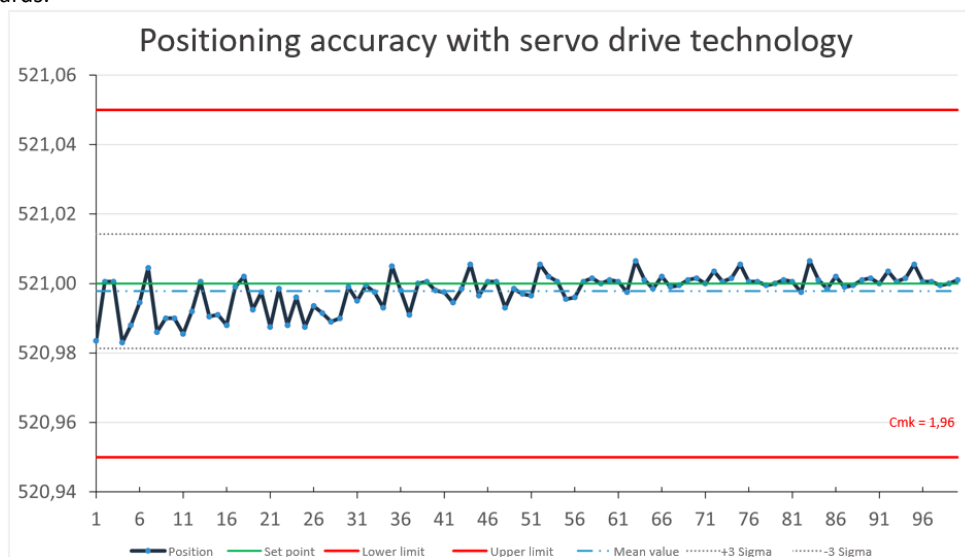

Figure 7: Sample distribution for proof of machine capability





The 275 (US) press was equipped with a servo drive with axial piston variable displacement pump for the ram and die cushion. This concept offers the user optimum process control, as all parameters relevant to the drawing process can be programmed precisely and repeatably. Measurements to prove the machine capability have shown that a c_{mk} value of 1.96 results for the positioning accuracy with a required tolerance of +/- 0.05 mm. The standard deviation achieved over 100 measurements is only 0.01 mm.

In addition, the system uses all the advantages of modern servo technology, such as reduction of throttle losses, reduction of tank volume and in particular, energy recuperation during the draw stroke.

Energy savings up to 40 %

Further measurements have shown further improved energy balances compared to the reference measurement. Here, the contributions from the reduced throttle losses and brake recuperation make a further contribution, so that **energy savings of up to 40% can be assumed** compared to the reference measurement. In the case of longer idle times or pressure holdings, this proportion can be correspondingly larger.

Further advantages are also clearly reflected in the queried peak power (active power) as well as the apparent power. **The peak load is reduced by approx. 20%, the apparent power is reduced by 80%¹. The total energy consumption can be reduced by more than 40% compared to conventional drive technology².**

The peak load is reduced by 20 %, the apparent power is reduced by 80 %¹. The total energy consumption can be reduced by more than 40 % compared to conventional drive technology².

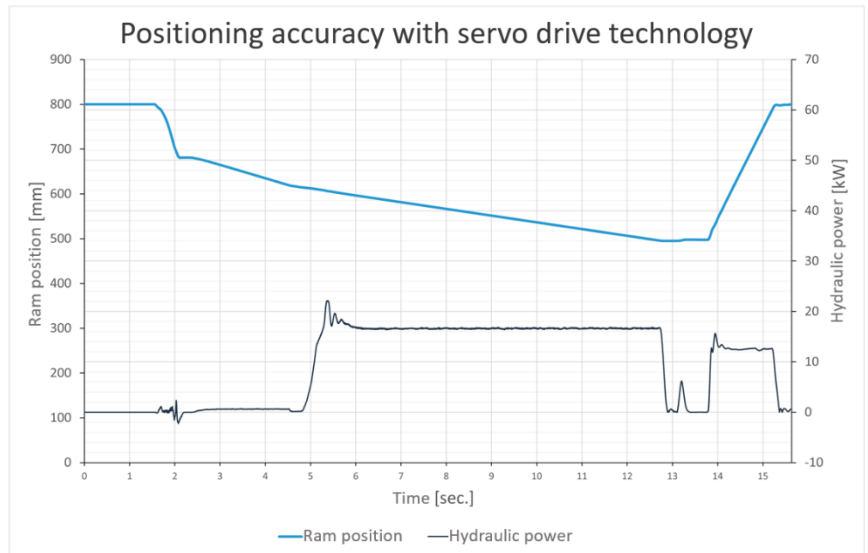

Figure 8: Reference stroke with hydraulic power

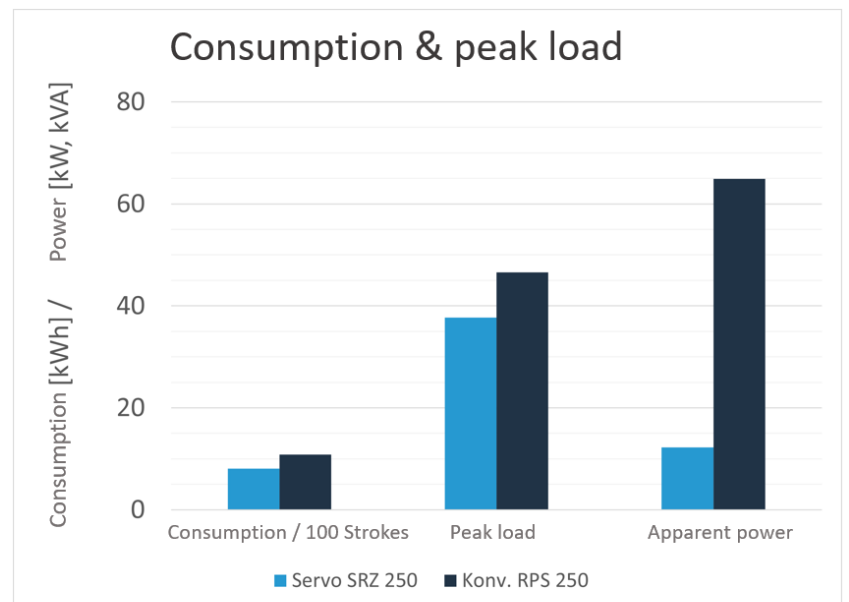

Figure 9: Energy consumption and power

¹ The reduction of apparent power can vary greatly depending on the reference and application case.
Note: Apparent power is an important design criterion for transformers and can cause further infrastructure costs in investment projects.
² The decisive factor for the comparison results is the technical status and the efficiency of the overall system, also the forming cycle on which it is based has a major influence on possible savings.





FURTHER OPTIONS TO INCREASE EFFICIENCY

In day-to-day production, it is not just purely physical variables such as power and energy consumption that play a role in efficiency. Organizational influences also have a decisive influence on the overall output of a company. The hydraulic press can also make an important contribution to this. LAUFFER has developed a number of options for this purpose, which have already been proven numerous times in practice.

A selection will be presented below as an example:

- **Integrated double blank detection**

The basis of the function is a real-time recording of each individual stroke, in particular, the parameters of pressing force and ram position. To activate the double sheet detection, a representative reference stroke is first recorded. After that, a permissible pressing force tolerance is specified. The control system of the press now recognizes on the basis of the set envelope whether the current pressing force with each increment of the ram stroke is within the tolerance band. If the pressing force leaves the defined tolerance band, an error reaction occurs. For this purpose, the user can choose between "Alarm message", "Alarm message and automatic stop at the end of the cycle" or "Alarm message and immediate stop". Measurements have shown that the press stops just a few milliseconds after leaving the tolerance band. The force applied is so sensitive that damage to the tool due to double blanks is avoided in any case, in real time.

- **Process Data Diagnosis**

The recording and storage of process data is now part of the documentation for many manufacturing companies. According to the state of the art, these are provided once a day in raw format³. However, in order to be able to use the data for error analysis and process optimization, it is needed directly at the machine. This results in an additional opportunity for entrepreneurial value creation. With the help of digital methods, process data can be visualized in such a way that deviations from target parameters are easily recognizable. Process data is also important for quality assurance and troubleshooting. The new LAUFFER press visualisation system LaHMI has such a visualisation tool. The user has access to the collected data immediately after the stroke has been completed and can analyze it in a diagram. After the analysis of target and actual data, changes can be made to the process control. In this way, quality can be improved and rejects are reduced. For complete documentation, all strokes are recorded and archived hourly as a ZIP file.

The Process Diagnostics menu offers the following useful functions:

- Individual structure of the diagram
- Filter and open past strokes (for reference)
- Show or hide individual process variables as well as auxiliary lines
- Cursor for precise examination of measured values with zoom function
- Export as PDF

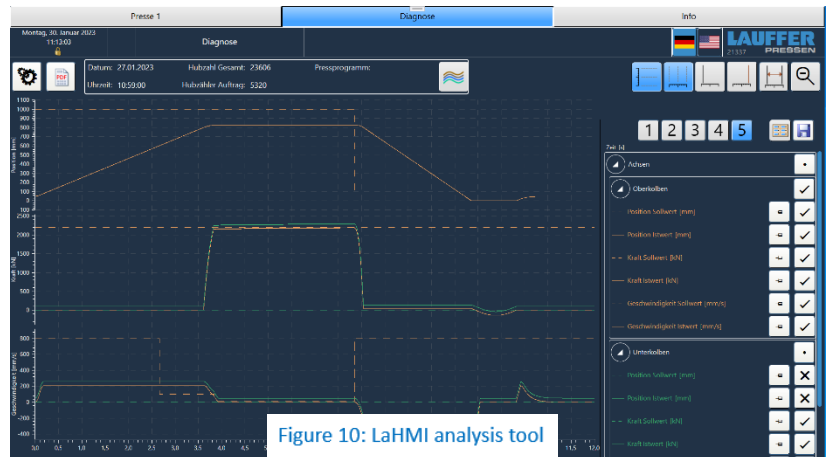

Figure 10: LaHMI analysis tool

³ See report: "Intelligent Data Visualization";
<https://www.elektrotechnik.vogel.de/nur-wer-seine-prozessdaten-sichtbar-macht-nutzt-sie-auch-effektiv-a-859319/>





- **Freely programmable step chain**

Flexibility and adaptivity are emerging as important success factors in times of increasing individualization and greater product diversity. Many producers have already recognized that this also applies to forming technology. In the context of sustainability, this trend is likely to manifest itself even further. The LAUFFER visualization (LaHMI for short) also addresses this with numerous functions.

An innovative further development is the freely programmable step chain, which enables the setter to design the sequence of the press stroke completely freely and individually. Programming is done graphically, supported by a symbol library for each movement and axis. For each process variable there is a separate track in which the command blocks can be arranged in order. Additional tracks for freely assignable inputs and outputs allow flexible transition conditions between two steps. In addition, force and waypoints of each individual axis and holding times can be linked.



Figure 11: Freely programmable LaHMI sequence programming

- **All-in-One HMI: Control and programming of external automation and tool functions via the LAUFFER visualization**

Many operators and setters are familiar with the situation when setting up a new product. Especially when it comes to a system with a coil feeding system, two machines must be coordinated with each other in terms of control technology. Commands for the feed must be set and these must be linked to corresponding start and stop conditions of the press stroke for the sequence of the step chain. Programming takes place on at least two input devices and if the product requires a different sequence of steps, it becomes complex.

For this purpose, LAUFFER offers an option to include the control of a conveyor system or external tool function as an integral part of the press control. This not only saves resources and costs for the customer, but also offers the easy possibility of flexibly programming several system components or external functions via one single input device (HMI). Start and stop signals can be linked easily and intuitively and the setter saves valuable time in recipe programming.

- **Predictive maintenance**

In addition to the selection of the appropriate drive, the economical operation of manufacturing plants also includes a well thought-out maintenance strategy. Preventive maintenance can be cited as the most effective measure against unplanned downtimes. In addition to planned, regular maintenance, this also consists of modern monitoring systems that collect and evaluate real-time operating data laying the groundwork for predictive maintenance. Data analysis and subsequent diagnosis for reliable damage prediction require a comprehensive database.

Together with the leading specialists in drive and control technology, LAUFFER is able to transmit the data with the required quality to a database on a daily basis. There, they are analyzed and evaluated with the help of self-learning algorithms and artificial intelligence. If known trends emerge for dedicated data that indicate foreseeable damage, the system sends an automated message to the customer. Thus, unplanned and costly failures can be avoided and machine availability remains at a high and reliable level.





DIVERSITY REQUIRES COMPETENCE

There are many options in the field of press drives. Each concept offers advantages and disadvantages in its own right and thus serves very special customer requirements. Traditional drive systems will continue to play an important role. In times of rising energy costs, however, it is becoming increasingly important to design the drive concept according to the range of applications with a focus on energy efficiency and sustainability. For this purpose, numerous high-performance systems are available on the market that have already proven themselves in practice.

As a press specialist, LAUFFER Pressen has the necessary experience and also attaches great importance to flexibility, because the right drive concept can only be selected if the individual case is considered in detail. Expertise, creativity and openness to innovation are important pillars in this joint approach. However, successful cooperation also requires willingness on the part of the customer. The provision of product information, production scenarios and forming parameters is a fundamental basis.

In addition, amortization considerations should be seen in the long term with regard to ROI. Amortizations within 2 years are too short-term despite rising energy prices, because environmental aspects have a long-term nature and require a structural rethinking of companies.

Many well-known traditional German companies are already setting a good example and investing in sustainable technologies for various reasons. The focus is less on the pure investment sum because it is planned for the long term and criteria of a holistic operating cost calculation are taken into account. The long-term success of these companies demonstrates that such a strategy is quite profitable and hopefully also serves as a role model for other companies.



Our application consultants will be happy to help you determine your specifications on site.
Contact us.

Maschinenfabrik Lauffer GmbH & Co. KG

Stefan Hildebrandt

LAUFFER Head of Sales, Forming Technology

T +49 7451 902-158 E stefan.hildebrandt@lauffer.de



www.lauffer.de